



The Right Connection®

Forged Steel Gate Valves 1/2" - 2" Welded Bonnet

*Gate Valves ANSI/API Class 150-800: our **bellows technology** keeps corrosive or harmful atmospheric conditions from entering the process.*



interior cut-away

Applications:

- For use in applications where leakage into or out of the valve is unacceptable such as heat transfer oil, toxic fluids, steam and regulated media.

Features:

- stainless steel bellows (Inconel™ bellows available) provides longer life and maximum corrosion resistance
- zero stem leakage eliminates media loss and satisfies environmental regulations
- zero maintenance results in lower operating costs / no downtime
- reduce monitoring costs
- three stem seals for safety: metallic bellows, graphite packing, backseat in open position
- hardfaced Stellite® 6 seating surface provides long life
- additional alloys, trims and other end configurations available

Standards:

- valve tested to ASME B16.34 / API 598
- meets MSS SP-117
- 5 year bellows warranty

Dixon Eagle

33 Plan Way - Building 5 • Warwick, RI 02886
ph 401.732.0333 • toll free 800.314.9246 • fx 401.732.2201
eaglesales@dixonvalve.com
dixonvalve.com

Materials

No.	Description	Carbon Steel (C22)
1	body	A105
2	seat ring	type 316 stainless ¹
3	bonnet	A105
4	extension	A105
5	gate	type 420 stainless
6	bellows assy.	type 321 stainless
7	stem	type 410 stainless
8	gland packing	graphite
9	gland bushing	type 410 stainless
10	gland plate	carbon steel
11	gland bolt	type 410 stainless
12	pin	type 410 stainless
13	hex nut	carbon steel
14	yoke sleeve	type 410 stainless
15	thrust collar	type 410 stainless
16	handwheel	malleable iron
17	handle nut	carbon steel
18	grease fitting	copper alloy
19	name plate	aluminum

¹ Stellite™ overlay on seating area. Stellite™ is a registered trademark of Thermadyne.

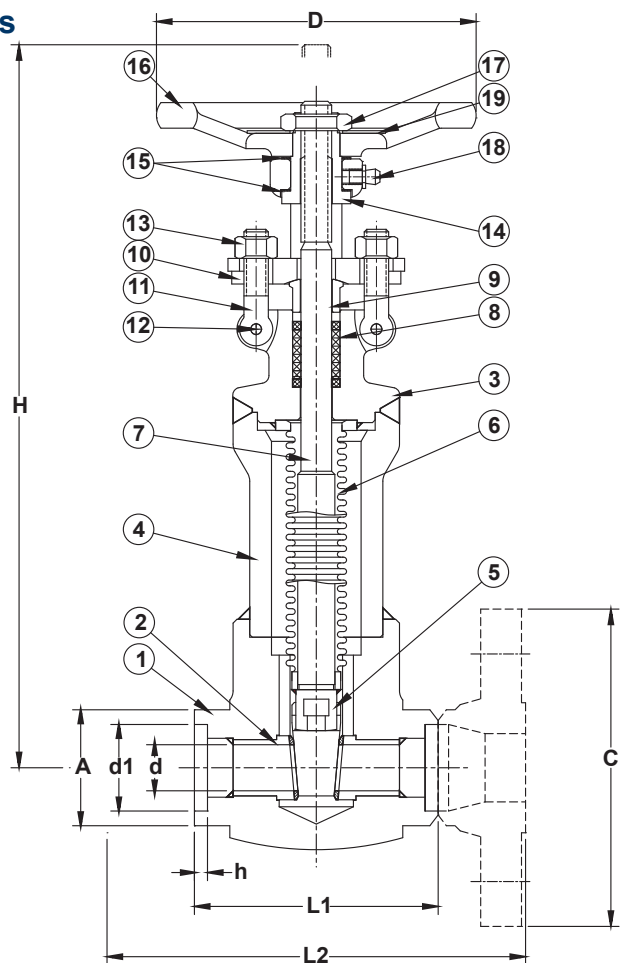

Operating Characteristics and Dimensions

Socket Weld / Threaded Gate Valves

Size	d	A	d1	h	L1	H	D	LIFT	Wt (lbs)	Cv
½	.39	1.34	.855	.39	3.11	9.8	3.94	.51	6.4	7.1
¾	.54	1.57	1.065	.51	3.62	10.9	3.94	.67	7.2	15.0
1	.71	1.93	1.330	.51	4.37	13.1	4.92	.87	11.0	25.0
1½	1.14	2.56	1.915	.51	4.72	17.0	6.30	1.34	20.0	75.0
2	1.45	3.07	2.406	.63	5.51	20.3	7.09	1.69	30.0	120.0

Flanged Gate Valves

Size	150			300			600		
	L2	C	Wt (lbs)	L2	C	Wt (lbs)	L2	C	Wt (lbs)
½	4.25	3.50	9.0	5.50	3.75	11	6.50	3.75	12
¾	4.62	3.88	11.0	6.00	4.62	15	7.50	4.62	16
1	5.00	4.25	15.0	6.50	4.88	19	8.50	4.88	21
1½	6.50	5.00	26.0	7.50	6.12	34	9.50	6.12	36
2	7.00	6.00	40.0	8.50	6.50	48	11.50	6.50	51

Warning & Safety



Dixon Eagle valves are designed to work safely for their intended use. Failure to know and understand the intended use or to consider the size, temperature, application, media, pressure and manufacturers recommendations when selecting the proper valve assembly components can result in accidents and injuries, including death and serious and permanent injuries. Dixon recommends that all valve assemblies be tested in accordance with ASME and API recommendations and be inspected regularly to ensure that their use remains appropriate and that they are not damaged.

At no charge, Dixon is available to consult, train and recommend the proper selection and application of all valves we sell. We strongly recommend that distributors and end users make use of Dixon's Testing and Recommendation Services. Call 800.355.1991 to learn more.

ph 401.732.0333 • toll free 800.314.9246 • fx 401.732.2201

eaglesales@dixonvalve.com

dixonvalve.com

Printed in the USA